



ZT483H, ZT485H

Low Power 5V 250kbps/10Mbps 256-Fanout RS485 Transceivers



Features

- Meets or exceeds the requirements of ANSI Standard TIA/EIA-485-A and ISO 8482:1987(E) specifications for V_{CC} at $+5V \pm 5\%$
- Low quiescent current – 0.5mA typ., 1mA max.
- Low shutdown current (where applicable) - 0.01 μ A typical, 10 μ A max.
- Guaranteed standard data rate 250kbps or 10Mbps
- True Fail-Safe (Open, Short, Bus Idle) Receiver
- Thermal shutdown protection
- -7V to +12V common-mode input voltage range
- Half-Duplex mode configuration
- Allows up to 1/8 unit load (256 devices) on the same common bus
- Controlled driver output slew rate and receiver input filtering
- Active-high driver enable and active-low receiver enable
- ESD protection on bus terminals
 ± 15 kV Human Body Model (HBM)
- Alternative replacement for MAX308x, MAX1308x, SN75HVD308x, SN65HVD308x
- Standard fanout driving 1 unit load (32 devices) on the ZT485E Series and 1/4 unit load (128 devices) higher fanout on the ZT485ER Series are available packaged options.
- ZT483HCW/485HCW die sales in wafer forms and ZT483HCX/485HCX in wafflepack forms options available

General Description

The ZT485H series devices are 5V differential data line transceivers for RS485/RS422 communication that consist of one driver and one receiver with high level of ESD protection. They are designed for balanced transmission lines interface that meet ANSI standard TIA/EIA-485-A and ISO 8482:1987(E) specifications.

The ZT485H series devices spans out with half or full duplex, data rate guaranteed at 250k bit per second or 10Mbps, and allow one-eighth of an unit load that fan out 256 devices sharing a common bus. The I/Os are enhanced-electrostatic discharge (ESD) protected, exceeding ± 15 kV Human Body Model (HBM).

Applications

- RS422/RS485 communications
- Utility meters
- Industrial process control
- Building automation
- Level translators
- Transceivers for EMI-sensitive applications
- Routers and HUBs
- Industrial-controlled Local Area Networks
- Industrial PCs, embedded PCs and peripherals
- Industrial, security CATV and camera applications

ZT483H/ZT485H

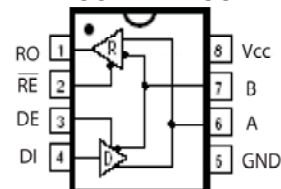

Product Selection Guide And Cross Reference

Part Number	Duplex	# Of Tx/Rx	Data Rate (Mbps)	# of Tx/Rx on Bus	Slew Rate Limit	Rx Input Filtering	Low-Power Shutdown	Tx/Rx Enable	ESD on Tx/Rx	Package Types	Pin-to-Pin Cross Reference
ZT483H	Half	1/1	0.25	256	Yes	Yes	Yes	Yes	± 15 kV	8-PDIP, 8-nSOIC	MAX3060, MAX3082E, SN65HVD3082E, SN75HVD3082E
ZT485H	Half	1/1	10	256	No	No	Yes	Yes	± 15 kV	8-PDIP, 8-nSOIC	MAX3085E, MAX3088E, MAX3089E, SN65HVD3085E



Absolute Maximum Ratings

These are stress ratings only and functional operation of the device at these ratings or any other above those indicated in the operation sections of the specifications is not implied. Exposure to absolute maximum rating conditions for extended periods of time may affect reliability.

Power Supply, (V_{CC})..... $-0.3V$ to $+6.0V$

Input Voltages

DI, DE, \overline{RE} (V_{IH}), High Input Voltage $+2V$ to $+6.0V$

DI, DE, \overline{RE} (V_{IL}), Low Input Voltage $0V$ to $+0.8V$

Differential Input Voltage, (V_{ID}) $-12V$ to $+12V$

A, B (V_I) $+12V$ to $-7V$

Output Voltages

RO $-0.3V$ to ($V_{CC} + 0.3V$)

Y, Z (A & B on ZT485H) $+12V$ to $-7V$

Operating Temperature..... $-40^{\circ}C$ to $+85^{\circ}C$

Storage Temperature..... $-65^{\circ}C$ to $+150^{\circ}C$

Power Dissipation Per Package

8-pin PDIP (derate $9.09mW/^{\circ}C$ above $+70^{\circ}C$) $722mW$

8-pin nSOIC (derate $6.14mW/^{\circ}C$ above $+70^{\circ}C$).... $500mW$

Storage Considerations

Storage in a low humidity environment is preferred. Large high density plastic packages are moisture sensitive and should be stored in Dry Vapor Barrier Bags. Prior to usage, the parts should remain bagged and stored below $40^{\circ}C$ and 60%RH. If the parts are removed from the bag, they should be used within 168 hours or stored in an environment at or below 20%RH. If the above conditions cannot be followed, the parts should be baked for 12 hours at $125^{\circ}C$ in order to remove moisture prior to soldering. Zywyn ships product in Dry Vapor Barrier Bags with a humidity indicator card and desiccant pack. The humidity indicator should be below 30%RH. The MSL of this product is 3.

The information furnished by Zywyn has been carefully reviewed for accuracy and reliability. Its application or use, however, is solely the responsibility of the user. No responsibility of the use of this information become part of the terms and conditions of any subsequent sales agreement with Zywyn. Specifications are subject to change without the responsibility for any infringement of patents or other rights of third parties which may result from its use. No license or proprietary rights are granted by implication or otherwise under any patent or patent rights of Zywyn Corporation.

DC Electrical Characteristics

Unless otherwise stated, $V_{CC} = +5.0V$, $T_A = T_{min}$ to T_{max} , typical values apply at $V_{CC} = +5.0V$ and $T_A = 25^\circ C$.

Parameter	Condition	Min	Typ	Max	Units
TTL Logic Input TTL Logic Output RS485 Input RS485 Output Power Pin	DE, DI, \overline{RE} RO A, B Y, Z V_{CC} , V_{GND}	High $Z_{O/P}$ when disabled High $Z_{O/P}$ when disabled			
Operating Voltage & Temp Temperature V_{CC} Voltage Range	Industrial Grade $V_{CC} = +5.0V$ Supply	-40 4.75	+25 5.0	+85 5.25	$^\circ C$ V
Supply Current I_{CC} , Tx and Rx active I_{CC} , Tx active I_{CC} , Rx active I_{SD} , Shutdown Current	DI= V_{CC}/GND , DE= V_{CC} , $\overline{RE}=GND$, RS485 I/P=Open DI= V_{CC}/GND , DE= V_{CC} , $\overline{RE}=V_{CC}$, RS485 I/P=Open DI= V_{CC}/GND , DE=GND, $\overline{RE}=GND$, RS485 I/P=Open DI= V_{CC}/GND , DE = GND, $\overline{RE} = V_{CC}$, RS485 I/P=Open		400 400 400 1.0	900 900 900 10	μA μA μA μA
High-Level Output Current I_{OH} , Driver I_{OH} , Receiver Low-Level Output Current I_{OL} , Driver I_{OL} , Receiver		-60 -8		60 4	mA mA mA mA
TTL LOGIC Input, Driver Input Threshold Low, V_{IL} Input Threshold High, V_{IH} TTL LOGIC Output, Receiver Output Voltage Low, V_{OL} Output Voltage High, V_{OH} Output Leakage Current Short Circuit Current	$V_{CC} = +5.0V$ Supply, DE, DI, and \overline{RE} $V_{CC} = +5.0V$ Supply, DE, DI, and \overline{RE} $I_{OUT} = +4mA$, Input Differential Voltage = 200mV $I_{OUT} = -4mA$, Input Differential Voltage = 200mV Receiver Outputs Disabled, $V_{OUT} = 0.4V$ to $2.4V$ $V_{OUT} = 0V$ to V_{CC}	2.0		0.8 0.4 3.5 ± 1 95	V V V V μA mA
Receiver Input Input Current Differential Threshold Voltage, V_{TH} Input Hysteresis Input Resistance, R_{IN}	DE = 0V, $V_{CC} = 0V$ to $5.25V$, $V_{IN} = +12V$ DE = 0V, $V_{CC} = 0V$ to $5.25V$, $V_{IN} = -7V$ $V_{CM} = 0V$, $V_{CC} = +5.0V$, $T_A = 25^\circ C$ $V_{CM} = 0V$ $V_{CM} = -7V$ to $+12V$	-0.2		1.0 -0.8 +0.2	mA mA V
Transmitter Output Differential Output Voltage, V_{OD} Differential Output Voltage, ΔV_{OD} Driver Common Mode Output Change in Voltage Magnitude for Complimentary States, ΔV_{OC} Change in Voltage Magnitude for Complimentary States, ΔV_{OC} Transmitter Short-Circuit Current	No Load With $R_L = 50\Omega$, $C_L = 50pF$, Refer to Figure 1. (RS422) With $R_L = 27\Omega$, $C_L = 50pF$, Refer to Figure 1. (RS485) With $R_L = 27\Omega$ or 50Ω . $C_L = 50pF$. Refer to Figure 3. Differential Output Voltage, with $R_L = 27\Omega$ or 50Ω , $C_L = 50pF$. Refer to Figure 1. Common-Mode Output Voltage, with $R_L = 60\Omega, 375\Omega, 375\Omega$. Refer to Figure 2. Output HIGH, $V_{OUT} = -7V$ to $+12V$. Refer to Figure 7. Output LOW, $V_{OUT} = -7V$ to $+12V$. Refer to Figure 7.	2 1.5		5 5 3 0.2 0.2 250 250	V V V V V mA mA

AC Electrical Characteristics (ZT485H)

Unless otherwise stated, $V_{CC} = +5.0V$, $T_A = T_{min}$ to T_{max} , typical values apply at $V_{CC} = +5.0V$ and $T_A = 25^\circ C$.

Parameter	Condition	Min	Typ	Max	Units
Transmitter Timing					
Transmitter Propagation t_{PLH}	$R_{DIFF} = 54\Omega$, $C_L = 50pF$. Refer to Figure 4.		35	60	ns
Transmitter Propagation t_{PHL}	$R_{DIFF} = 54\Omega$, $C_L = 50pF$. Refer to Figure 4.		35	60	ns
Transmitter Output Skew t_{SK}	$ t_{PLH} - t_{PHL} $		3	10	ns
Transmitter Rise/Fall Time	t_r, t_f , $R_{DIFF} = 54\Omega$, $C_L = 50pF$, Refer to Figure 4.		15	25	ns
Transmitter Output Enable	To Output HIGH, $C_L = 50pF$, $R_L = 110\Omega$. Refer to Figure 5. To Output LOW, $C_L = 50pF$, $R_L = 110\Omega$. Refer to Figure 6.		50		ns
Transmitter Output Disable	From Output HIGH, $C_L = 50pF$, $R_L = 110\Omega$. Refer to Figure 5. From Output LOW, $C_L = 50pF$, $R_L = 110\Omega$. Refer to Figure 6.		50		ns
Receiver Timing					
Receiver Propagation t_{PLH}	$C_L = 15pF$, Refer to Figure 9.		50	150	ns
Receiver Propagation t_{PHL}	$C_L = 15pF$, Refer to Figure 9.		50	150	ns
Differential Receiver Skew t_{SK}	$ t_{PHL} - t_{PLH} $		10		ns
Receiver Output Enable	To Output HIGH, $C_L = 15pF$. Refer to Figure 10. To Output LOW, $C_L = 15pF$. Refer to Figure 11.		50		ns
Receiver Output Disable	From Output HIGH, $C_L = 15pF$. Refer to Figure 10. From Output LOW, $C_L = 15pF$. Refer to Figure 11.		50		ns
Shutdown Timing					
Time to Shutdown, t_{SHDN}		50	200	600	ns
Transmitter Enable from SHUTDOWN to Output HIGH	$C_L = 50pF$, $R_L = 110\Omega$. Refer to Figure 5.		200		ns
Transmitter Enable from SHUTDOWN to Output LOW	$C_L = 50pF$, $R_L = 110\Omega$. Refer to Figure 6.		200		ns
Receiver Enable from SHUTDOWN to Output HIGH	$C_L = 15pF$, $R_L = 1k\Omega$. Refer to Figure 11.		200		ns
Receiver Enable from SHUTDOWN to Output LOW	$C_L = 15pF$, $R_L = 1k\Omega$. Refer to Figure 11.		200		ns
Transceiver Throughput					
Maximum Data Rate	$R_L = 54\Omega$, $C_L = 50pF$, $T_A = 25^\circ C$	10			Mbps
ESD Tolerance					
ESD HBM	RS485 Inputs and Outputs		± 15		kV

AC Electrical Characteristics (ZT483H)

Unless otherwise stated, $V_{CC} = +5.0V$, $T_A = T_{min}$ to T_{max} , typical values apply at $V_{CC} = +5.0V$ and $T_A = 25^\circ C$.

Parameter	Condition	Min	Typ	Max	Units
Transmitter Timing					
Transmitter Propagation t_{PLH}	$R_{DIFF} = 54\Omega$, $C_L = 50pF$. Refer to Figure 4.	250	800	2000	ns
Transmitter Propagation t_{PHL}	$R_{DIFF} = 54\Omega$, $C_L = 50pF$. Refer to Figure 4.	250	800	2000	ns
Transmitter Output Skew t_{SK}	$ t_{PLH} - t_{PHL} $		20	800	ns
Transmitter Rise/Fall Time	t_r , t_f , $R_{DIFF} = 54\Omega$, $C_L = 50pF$, Refer to Figure 4.	250		2000	ns
Transmitter Output Enable	To Output HIGH, $C_L = 50pF$, $R_L = 110\Omega$. Refer to Figure 5. To Output LOW, $C_L = 50pF$, $R_L = 110\Omega$. Refer to Figure 6.		100		ns
Transmitter Output Disable	From Output HIGH, $C_L = 15pF$, $R_L = 110\Omega$. Refer to Figure 5. From Output LOW, $C_L = 15pF$, $R_L = 110\Omega$. Refer to Figure 6.		100		ns
Receiver Timing					
Receiver Propagation t_{PLH}	$C_L = 15pF$, Refer to Figure 9.	250		2000	ns
Receiver Propagation t_{PHL}	$C_L = 15pF$, Refer to Figure 9.	250		2000	ns
Differential Receiver Skew t_{SK}	$ t_{PHL} - t_{PLH} $		10		ns
Receiver Output Enable	To Output HIGH, $C_L = 15pF$, Refer to Figure 10. To Output LOW, $C_L = 15pF$, Refer to Figure 11.		100		ns
Receiver Output Disable	From Output HIGH, $C_L = 15pF$, Refer to Figure 10. From Output LOW, $C_L = 15pF$, Refer to Figure 11.		100		ns
Shutdown Timing					
Time to Shutdown, t_{SHDN}		50	200	600	ns
Transmitter Enable from SHUTDOWN to Output HIGH	$C_L = 50pF$, $R_L = 110\Omega$. Refer to Figure 5.		200		ns
Transmitter Enable from SHUTDOWN to Output LOW	$C_L = 50pF$, $R_L = 110\Omega$. Refer to Figure 6.		200		ns
Receiver Enable from SHUTDOWN to Output HIGH	$C_L = 15pF$, $R_L = 1k\Omega$. Refer to Figure 11.		200		ns
Receiver Enable from SHUTDOWN to Output LOW	$C_L = 15pF$, $R_L = 1k\Omega$. Refer to Figure 11.		200		ns
Transceiver Throughput					
Maximum Data Rate	$R_L = 54\Omega$, $C_L = 50pF$, $T_A = 25^\circ C$.	0.25			Mbps
ESD Tolerance					
ESD HBM	RS485 Inputs and Outputs		± 15		kV

Pin Description

(ZT483H/ZT485H)

Pin Numbers	Name	Description
1	RO	Receiver Output. If A>B by 200mV, then RO = HIGH; If A<B by 200mV, then RO = LOW
2	\overline{RE}	Receiver Output Enable. Low active input. RO is high-Z when \overline{RE} = HIGH
3	DE	Driver Output Enable. The transmitter outputs, Y and Z, are enabled when DE = HIGH. The outputs are high-Z when DE = LOW.
4	DI	Driver Input. A low on DI forces output Y low and output Z high. A high on DI will bring output Y high and output Z low.
5	GND	Analog Ground
6	A	Non-inverting transmitter output and non-inverting receiver input.
7	B	Inverting transmitter output and inverting receiver input.
8	V _{CC}	Power Supply Input, +5V ±5%

Bonding Diagram

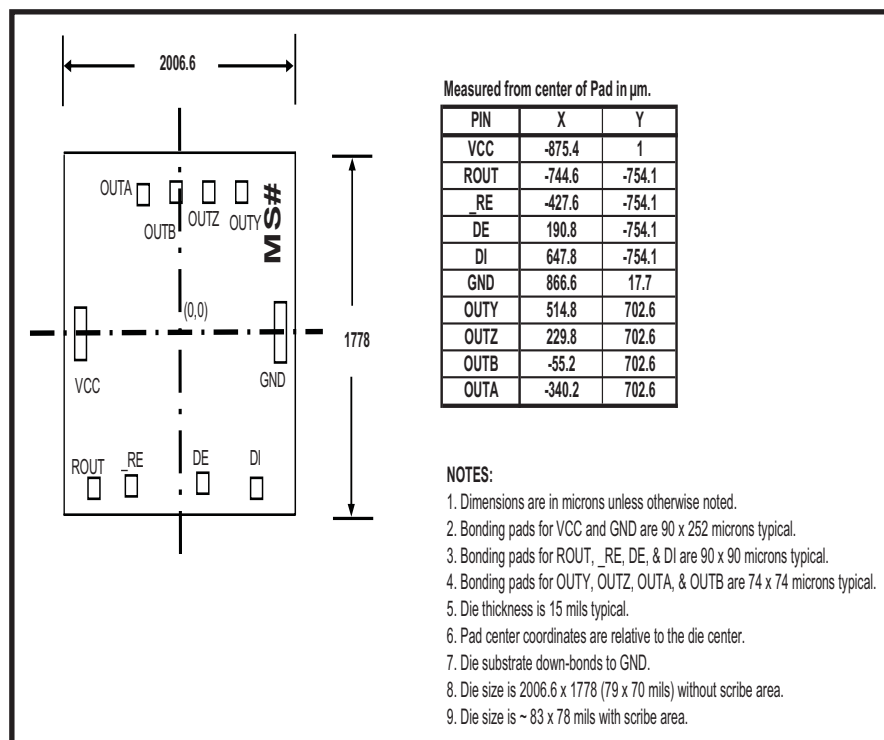

Die Photo

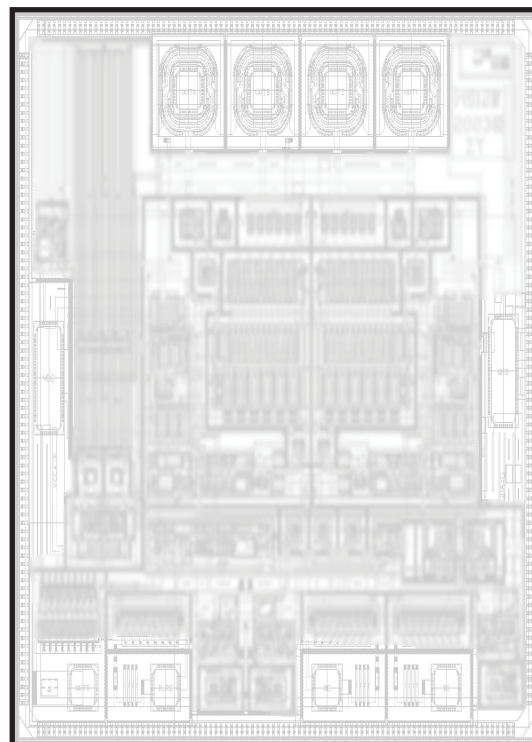

Circuit Description

The ZT483H and ZT485H are low-power transceivers for RS-485 and RS-422 communications. The RS-485 standard is ideal for multi-drop applications and for long-distance interfaces. The TIA/EIA-485 specification allows up to 256 drivers and 256 receivers to be connected to a data bus, making it an ideal choice for multi-drop applications. RS-485 transceivers are equipped with a wide (-7V to +12V) common mode range to accommodate ground potential differences since the cabling can be as long as 4,000 feet. As RS-485 is a differential interface, data is virtually immune to noise in the transmission line.

The ZT483H is slew-rate limited, minimizing EMI and reducing reflections caused by improperly terminated cables.

RS-485 Transmitters

Each device in the ZT485H family contains a differential output line transmitter that can drive voltage into multiple loads on a terminated two-wire pair, and a receiver that accepts a differential voltage down to 200mV. The transmitter's differential output can comply with RS-485 and also RS-422 standards. The typical voltage output swing with no load is 0V to V_{CC} . With worst case loading of 54 ohms across the differential outputs, the drivers can maintain greater than 1.5V voltage levels, which is more than adequate for a differential receiver to acknowledge a logic state. The 54 ohms is the equivalent of two 120 ohm termination resistors placed on each side of the transmission line and the input impedance of 256 receivers on the line. The ZT485H transmitter has an enable control line which is active HIGH. A logic HIGH on DE (pin 3) will enable the differential outputs. A logic LOW on DE (pin 3) will disable the transmitter outputs. While disabled, the transmitter outputs are in high impedance.

RS-485 Receivers

Each transceiver contains one differential receiver that has an input sensitivity of 200mV. The input impedance of the receivers is typically 96 kohms. A wide common mode range of -7V to +12V allows for large ground potential differences between systems.

The ZT485H receivers have an enable control input. A logic LOW on \overline{RE} will enable the receiver, a logic HIGH on \overline{RE} will disable the receiver. The receivers are equipped with the true fail-safe feature, which guarantees that the receiver output to be in a HIGH-IMPEDANCE state when the input is left unconnected. When the receiver inputs are either open or short circuit, the receiver output will be in a HIGH state when RE enable is LOW.

The ZT485H transmits and receives at data rates up to 10Mbps. The ZT483H operates with data rates up to 250kbps.

Bus Configuration

The ZT483H and ZT485H are both configured as half-duplex RS485/RS422 transceivers.

Half duplex is a configuration where the transmitter outputs are connected to its receiver inputs. This application is common for two-wire interfaces where either the transmitter is active or the receiver is active. It is common to connect the enable inputs for the transmitter and receiver together so that a logic HIGH will enable the transmitter and disable the receiver. Conversely, a logic LOW will disable the transmitter and enable the receiver. Half-duplex configurations and these devices are designed for bidirectional data transmission on multipoint twisted-pair cables for applications, such as digital motor controllers, remote sensors and terminals, industrial process control, security stations and environmental control systems.

ESD Immunity

Electro-Static Discharge (ESD) is an important factor when implementing a serial port into a system, especially in harsh environmental conditions. These industrial strength devices provide extra protection against ESD and are intended for harsh environments where high-speed data communication is important.

All of the ZT485H family of transceivers incorporate internal protection structures on all pins to protect against ESD charges encountered during handling and assembly. The driver outputs and receiver inputs have extra protection against static electricity as they are directly interfacing to the outside environment. As such, these pins against ESD of $\pm 15kV$ without damage in all states of the transceiver's operation in the static state. After multiple ESD events, Zywyn's ZT485H family of transceivers keep working without latchup. These devices eliminate the need for external transient suppressor diodes and the associated high capacitance loading, allowing reliable high-speed data communications.

The Human Body Model has been the generally accepted ESD testing method for semiconductors. This test is intended to simulate the human body's potential to store electrostatic energy and discharge it to an integrated circuit upon close proximity or contact. This method will test the IC's capability to withstand an ESD transient during normal handling such as in manufacturing areas where the ICs tend to be handled frequently.

Function Table

ZT483H/ZT485H

DRIVER				RECEIVER		
Input DI	Enable DE	Outputs		Differential Inputs $V_{ID} = V_A - V_B$	Enable \overline{RE}	Output RO
		A	B			
H	H	H	L	$V_{ID} \leq -0.2V$	L	L
L	H	L	H	$-0.2V < V_{ID} < +0.2V$	L	U
X	L	Z	Z	$+0.2V \leq V_{ID}$	L	H
Open	H	H	L	X	H	Z
X	Open	Z	Z	Open circuit	L	H
				Short circuit	L	H
				X	Open	Z

Note:

H = High Level; L = Low Level; Z = High Impedance; X = Irrelevant; U = Undetermined State.

Pin Configuration

ZT483H/ZT485H

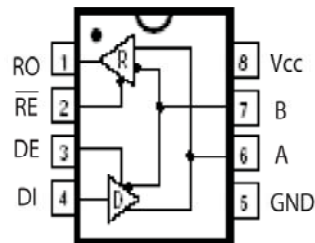

8-Pin PDIP/nSOIC

Typical Application Circuits

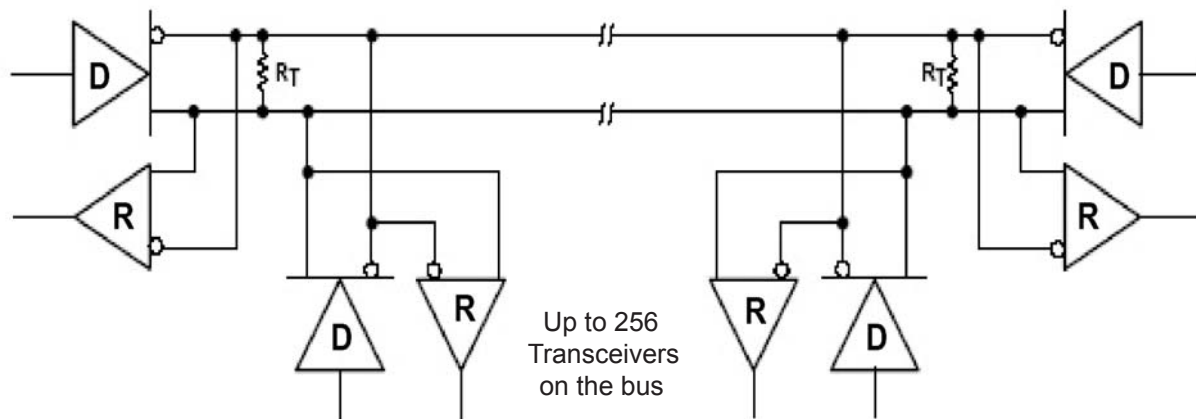

Notes:

- A. The bus should be terminated at both ends in its characteristic impedance of $R_T = Z_0$.
- B. Stub lengths off the main bus should be kept as short as possible.
- C. Can connect up to 256 devices on the same common bus.

Typical Test Circuits

Notes:

- A. The test load capacitance includes probe and test jig capacitance, unless otherwise specified.
- B. The signal generator had the following characteristics:
Pulse rate = 1000 kHz, 50% duty cycle, $Z_O = 50\Omega$, t_r & $t_f < 6ns$, unless otherwise specified.

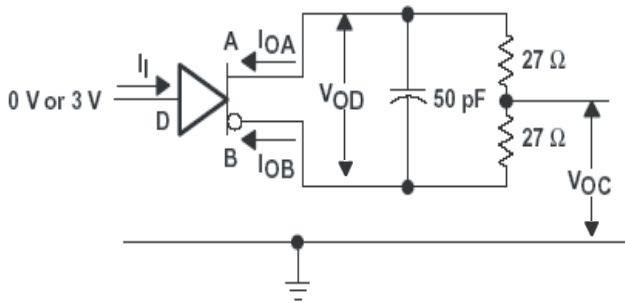

Figure 1. Driver Test Circuit, V_{OD} and V_{OC} Without Common-Mode Loading

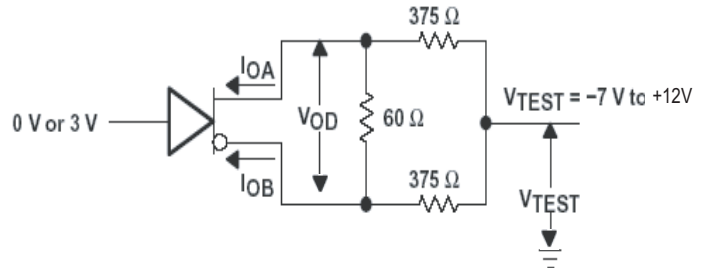

Figure 2. Driver Test Circuit, V_{OD} With Common-Mode Loading

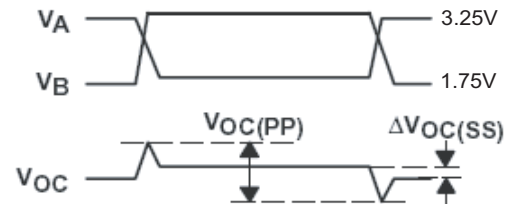
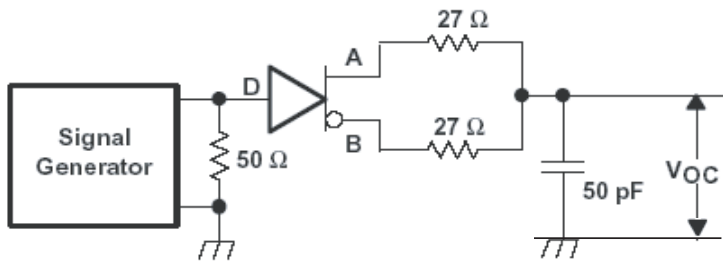

Figure 3. Driver Common-Mode Output Voltage (V_{OC}) Test Circuit and Waveforms

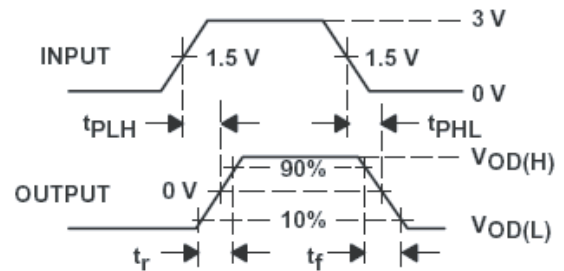
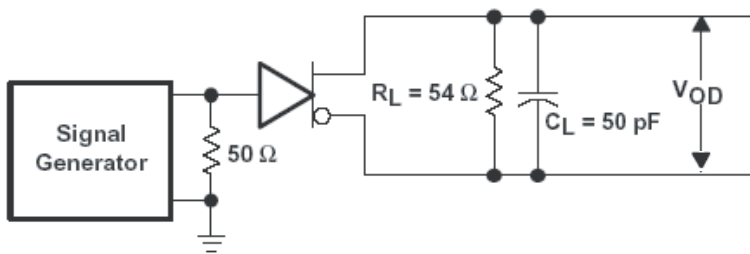

Figure 4. Driver Differential Output Voltage (V_{OD}) Switching Test Circuit and Waveforms

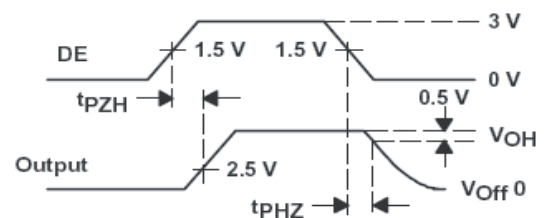
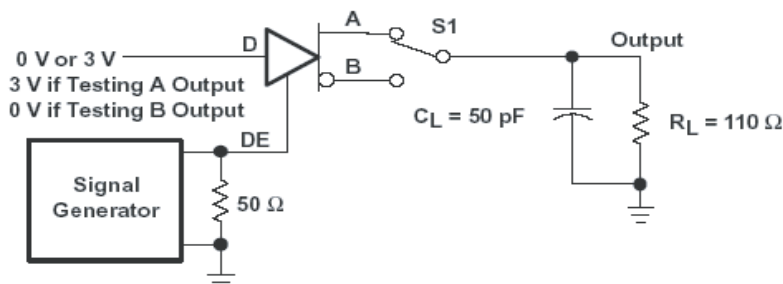

Figure 5. Driver Enable/Disable Test Circuit and Waveforms, High Output

Typical Test Circuits

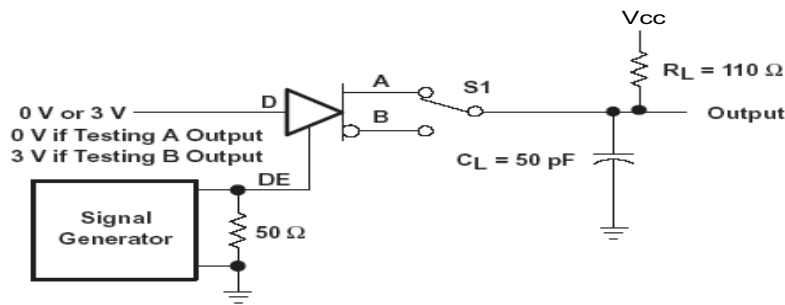

Figure 6. Driver Enable/Disable Test Circuit and Waveforms, Low Output

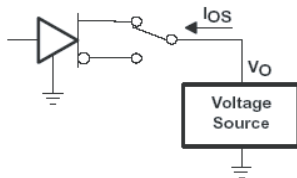

Figure 7. Driver Short-Circuit Test Configuration

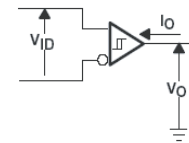

Figure 8. Receiver Parameter Definitions

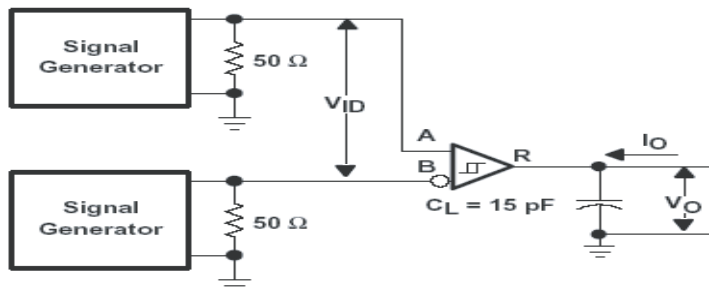

Figure 9. Receiver Propagation (t_{PLH} and t_{PHL}) Test Circuit and Waveforms

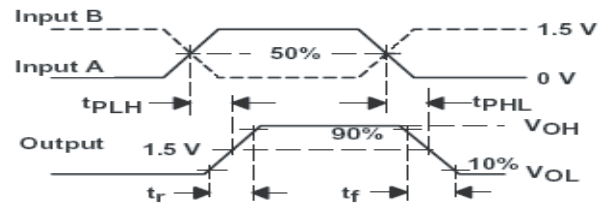

Figure 10. Receiver Output Enable/Disable Test Circuit and Waveforms, Data Output High

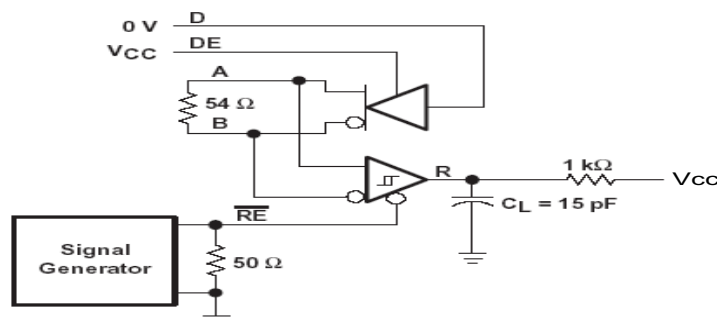
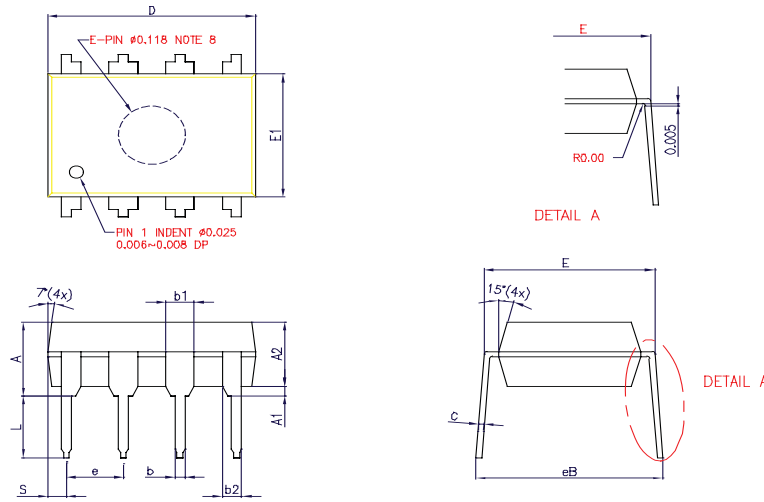

Figure 11. Receiver Output Enable/Disable Test Circuit and Waveforms, Data Output Low

Package Information



- NOTE :
- CONTROLLING DIMENSION : INCH
 - LEAD FRAME MATERIAL : C194
 - DIMENSION D AND E1 DO NOT INCLUDE MOLD FLASH OR PROTRUSIONS. MOLD FLASH OR PROTRUSIONS SHALL NOT EXCEED 0.010" [0.25mm]
 - DIMENSION "b1" DO NOT INCLUDE DAMBAR PROTRUSION. DAMBAR PROTRUSIONS SHALL NOT EXCEED 0.010" [0.25mm]. DISTANCE BETWEEN LEADS INCLUDING DAMBAR PROTRUSIONS TO BE 0.005" [0.13mm] MINIMUM.
 - TOLERANCE : ±0.010" [0.25mm] UNLESS OTHERWISE SPECIFIED.
 - OTHERWISE DIMENSION FOLLOW ACCEPTABLE SPEC.
 - REFERENCE DOCUMENT : JEDEC SPEC MS-001-BA
 - BOTTOM E-PIN INDENT ARE MARKED AS BELOW:



X : A ~ T
Y : 0 ~ 9

SYMBOLS	DIMENSIONS IN MILLIMETERS			DIMENSIONS IN INCHES		
	MIN	NOM	MAX	MIN	NOM	MAX
A	3.6	3.9	4.2	0.142	0.154	0.165
A1	0.38	—	—	0.015	—	—
A2	3.25	3.30	3.45	0.128	0.130	0.136
b	0.38	0.48	0.56	0.015	0.019	0.022
b1	1.48	1.58	1.88	0.058	0.062	0.074
b2	0.813	0.99	1.14	0.032	0.039	0.045
C	0.20	0.25	0.30	0.008	0.010	0.012
D	9.12	9.30	9.53	0.359	0.366	0.375
E	7.62	7.87	8.26	0.300	0.310	0.325
E1	6.20	6.35	6.60	0.244	0.250	0.260
e	—	2.54	—	—	0.100	—
eB	8.38	—	9.40	0.330	—	0.370
L	3.18	—	—	0.125	—	—
S	0.71	0.84	0.97	0.028	0.033	0.038

8-pin PDIP

CUSTOMER :		ZYWYN CORPORATION	
APPROVED BY	DATE	TITLE :	
DRAW BY: Sandy Liu	01/24/00	8L P-DIP PACKAGE OUTLINE DRAWING FOR MITSUMI	
CHECK BY: Leo Chen	01/28/00	DWG. NO. PO-DIP-019	REV. 0
APPROVAL: Paul Liu	01/27/00	UNIT : INCH	SCALE : 6/1 SHEET 1 OF 1
APPROVAL: Barry Chen	1/27/00		

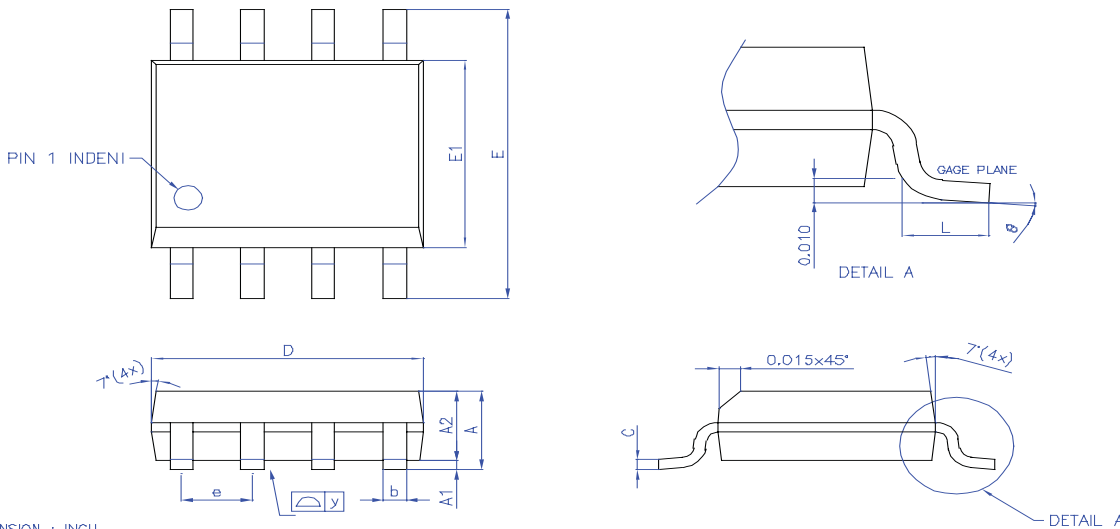

- NOTE :
- CONTROLLING DIMENSION : INCH
 - LEAD FRAME MATERIAL : COPPER 194
 - DIMENSION "D" DOES NOT INCLUDE MOLD FLASH, TIE BAR BURRS AND GATE BURRS. MOLD FLASH, TIE BAR BURRS AND GATE BURRS SHALL NOT EXCEED 0.006" [0.15mm] PER END DIMENSION "E1" DOES NOT INCLUDE INTERLEAD FLASH. INTERLEAD FLASH SHALL NOT EXCEED 0.010" [0.25mm] PER SIDE.
 - DIMENSION "b" DOES NOT INCLUDE DAMBAR PROTRUSION. ALLOWABLE DAMBAR PROTRUSION SHALL BE 0.003" [0.08mm] TOTAL IN EXCESS OF THE "b" DIMENSION AT MAXIMUM MATERIAL CONDITION. DAMBAR CANNOT BE LOCATED ON THE LOWER RADIUS OR THE FOOT. MINIMUM SPACE BETWEEN PROTRUSION AND AN ADJACENT LEAD TO BE 0.0028" [0.07mm]
 - TOLERANCE : ±0.010" [0.25mm] UNLESS OTHERWISE SPECIFIED.
 - OTHERWISE DIMENSION FOLLOW ACCEPTABLE SPEC.
 - REFERENCE DOCUMENT : JEDEC SPEC MS-012

SYMBOLS	DIMENSIONS IN MILLIMETERS			DIMENSIONS IN INCHES		
	MIN	NOM	MAX	MIN	NOM	MAX
A	1.47	1.60	1.73	0.058	0.063	0.068
A1	0.10	—	0.25	0.004	—	0.010
A2	—	1.45	—	—	0.057	—
b	0.33	0.41	0.51	0.013	0.016	0.020
C	0.19	0.20	0.25	0.0075	0.008	0.0098
D	4.80	4.85	4.95	0.189	0.191	0.195
E	5.80	6.00	6.20	0.228	0.236	0.244
E1	3.80	3.90	4.00	0.150	0.154	0.157
e	—	1.27	—	—	0.050	—
L	0.40	0.71	1.27	0.015	0.028	0.050
y	—	—	0.076	—	—	0.003
Ø	0"	—	8"	0"	—	8"

8-pin nSOIC

CUSTOMER :		ZYWYN CORPORATION	
APPROVED BY	DATE	TITLE :	
DRAW BY: Leo Chen	02/21/01	8L NARROW BODY SMALL OUTLINE PACKAGE DRAWING	
CHECK BY: Sandy Liu	02/11/01	DWG. NO. PO-SOP-001	REV. 2
APPROVAL: Barry Chen	02/21/01	UNIT : INCH	SCALE : 15/1 SHEET 1 OF 1
APPROVAL: Barry Chen	02/21/01		





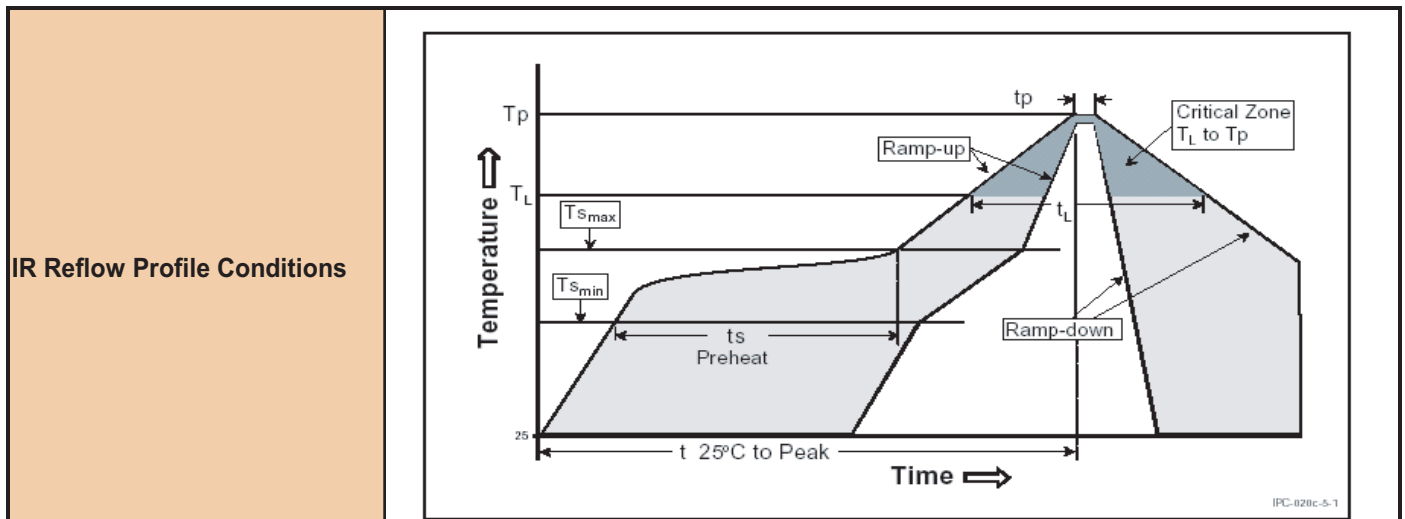

Green Package SMD IR Reflow Profile Information



Profile Feature	JESD Sn-Pb Eutectic Assembly	JESD Pb-free Assembly
Average Ramp-Up Rate (T_{Smax} to T_p)	3°C/seconds max.	3°C/seconds max.
Pre-heat		
- Temperature Min (T_{Smin})	100°C	150°C
- Temperature Max (T_{Smax})	150°C	200°C
- Time (T_{Smin} to t_{Smax})	60~120 seconds	60~180 seconds
Time maintained above:		
- Temperature (T_L)	183°C	217°C
- Time (t_L)	60~150 seconds	60~150 seconds
Peak/Classification Temperature (T_p)	235°C+5/-0°C	255°C+5/-0°C
Time within 5°C of actual Peak Temperature (t_p)	10~30 seconds	20~40 seconds
Ramp-Down Rate	6°C/second max.	6°C/second max.
Time 25°C to Peak Temperature	6 minutes max.	8 minutes max.

Zywyn Green Packages are Pb-free and RoHS compliance.

Ordering Information

Part Number	Temperature Range	Package Type (Green)	MOQ/Tube	MOQ/T&R
ZT483HLEEN	-40°C to +85°C	8-pin nSOIC 	100	2500
ZT483HLEEP	-40°C to +85°C	8-pin PDIP 	60	N/A
ZT483HCW	0°C to +70°C	Die in Wafer Forms	CF	N/A
ZT483HCX	0°C to +70°C	Die in Wafflepack Forms	CF	N/A
ZT485HLEEN	-40°C to +85°C	8-pin nSOIC 	100	2500
ZT485HLEEP	-40°C to +85°C	8-pin PDIP 	60	N/A
ZT485HCW	0°C to +70°C	Die in Wafer Forms	CF	N/A
ZT485HCX	0°C to +70°C	Die in Wafflepack Forms	CF	N/A

Please contact the factory for pricing, availability on Tape-and-Reel and Die Sales options.

CF = Contact Factory

Part Marking Information

TOPSIDE MARK INSTRUCTIONS:

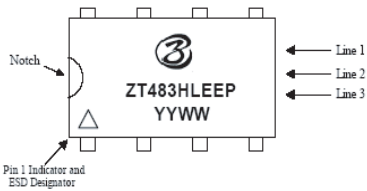

Line 1: Zywyn (logo)
 Line 2: Zywyn Part Number "ZT483HLEEP"
 Line 3: Date Code: (Last 2 digits of Prod. Year & Prod. Work Week)
 Note: Pin # 1 "△" Indicator Required

BOTTOMSIDE MARK INSTRUCTIONS:

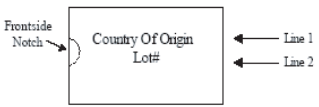

Line 1: Country of Origin (optional if Country of Origin is in Ejector Pin)
 Line 2: Lot Number

8-pin PDIP

TOPSIDE MARK INSTRUCTIONS:

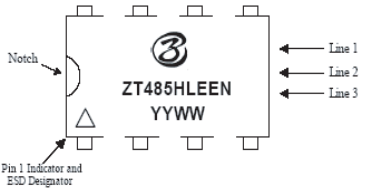

Line 1: Zywyn (logo)
 Line 2: Zywyn Part Number "ZT485HLEEN"
 Line 3: Date Code: (Last 2 digits of Prod. Year & Prod. Work Week)
 Note: Pin # 1 "△" Indicator Required

BOTTOMSIDE MARK INSTRUCTIONS:

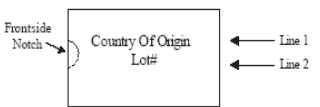

Line 1: Country of Origin (optional if Country of Origin is in Ejector Pin)
 Line 2: Lot Number

8-pin nSOIC

Zywyn Corporation

Headquarters and Sales Office

1270 Oakmead Parkway, Suite 201 • Sunnyvale, CA 94085 • Tel: (408) 733-3225 • Fax: (408) 733-3206

Email: sales@zywyn.com • www.zywyn.com

Zywyn Corporation reserves the right to make changes to any products described herein. Zywyn does not assume any liability arising out of the application or use of any product or circuit described herein; neither does it convey any license under its patent rights nor the rights of others.

© 2010 Zywyn Corporation



Specifications subject to change without notice